

GEORGETOWN MUNICIPAL LIGHT DEPARTMENT

INSTRUCTIONS TO DEVELOPERS AND CONTRACTORS  
FOR UNDERGROUND ELECTRICAL FACILITIES  
FOR SUBDIVISION HOUSING PROJECTS

CONTENTS

PART 1 - DEVELOPER/CONTRACTOR AND DEPARTMENT RESPONSIBILITIES

PART 2 - LAYOUT AND SIZING OF FACILITIES

PART 3 - EQUIPMENT SPECIFICATIONS

PART 4 - INSTALLATION SPECIFICATIONS

PART 5 - INSTALLATION DETAIL SHEETS

REVISED 3/3/00

# INSTRUCTIONS TO DEVELOPERS AND CONTRACTORS FOR UNDERGROUND ELECTRICAL FACILITIES FOR SUBDIVISION HOUSING PROJECTS

## PART 1 - DEVELOPER/CONTRACTOR AND DEPARTMENT RESPONSIBILITIES

### General:

This document provides specific instructions for the provision of underground electrical facilities associated with the construction of subdivision housing projects within the Town of Georgetown and interconnected to Georgetown Municipal Light Department's (GMLD or Department) primary distribution system.

The Town of Georgetown requires that all new residential developments be served by underground electrical systems. In order to maintain the highest level of service reliability, the Department's underground residential distribution (URD) systems employ the use of a conduit system (box pads, secondary connection pedestals and ducts) and padmount transformers and sectionalizing cabinets.

Developers and their electrical Contractors shall make no deviation from the instructions or specification provided herein without the expressed written permission of the Georgetown Municipal Light Department. Topics covered within this document include the following:

1. Electrical Contractor Qualifications
2. Developer's and Contractor's Responsibilities
3. Electric Department Responsibilities
4. Layout and Sizing of Facilities
5. Equipment Specifications
6. Installation Specifications
7. Installation Detail Sheets

### Electrical Contractor Qualifications

In order to ensure that the installation of the electrical and street lighting systems is accomplished by experienced personnel with the proper equipment, Developer shall submit the following qualification information for the electrical Contractor proposed for the project. If the Developer changes electrical Contractor, Developer shall notify Department immediately of such change and within 5 days resubmit the following qualification information for the new electrical Contractor proposed for the project.

1. Name, street address, telephone number and principal contact of Contractor
2. Number of years Contractor has been in business and number of years Contractor has been installing medium voltage URD and street lighting systems
3. List of projects of similar character completed by Contractor in last 5-10 years as follows:  

<u>Year</u>	<u>Owner/Telephone</u>	<u>Location/Description</u>	<u># of Homes</u>
-------------	------------------------	-----------------------------	-------------------
4. Name of Contractor's full time project/site manager and staff to be assigned to the project and their experience background including appropriate licenses, training schools and/or certificates

5. List of equipment proposed to be used on the project
6. Written procedures describing how the work will be accomplished.

### Developer's and Contractor's Responsibilities

The Developer and/or Contractor shall be responsible for the following items:

1. Granting or furnishing an easement for all electric facilities. The electric utility easement requirement will be outlined by the Department and will consist of three (3) parts: (a) a ten (10) foot wide strip (or cable easement) along all front (or street) property lines, (b) a five (5) foot wide street crossing from front property line to front property line wherever cable crossings are required, and (c) a typical maximum twenty-two feet wide by twelve feet deep (22'Wx12'D) equipment easement for sectionalizing cabinet/padmout transformer installations or twelve feet wide by twelve feet deep (12'Wx12'D) equipment easement for padmount transformer installations at front lot corner(s) and located equally on each lot. The actual easement requirements are project dependent. Therefore, these minimum requirements may be supplemented by additional easement requirements, as necessary, by the design of the development and associated electric and street light facilities. The transformers, sectionalizing cabinets, secondary connection pedestals and appurtenances will be installed where required on the equipment easements.
2. Providing the Department with copies of Subdivision Drawings and Developer Load Data and drawing CAD files of the recorded plans approved by the Town of Georgetown showing the complete layout of the development, as follows:
  - a. Two complete sets of Town approved subdivision drawings prepared by the Developer's civil engineer and illustrating the physical layout of all subdivision facilities shall be provided to the Department for review and use by the Department's Consultant. Physical drawings shall be to 1" - 40' scale and include topographic plans and indicate the layout of all lots, proposed location of all houses, driveways, septic systems, streets, sidewalks, above ground and buried drainage facilities, water, gas, telephone and cable utilities and facilities.
  - b. Developer shall also provide AutoCad files of all approved subdivision drawings or mylar reproducibles of each of the drawings if AutoCad files are not available.
  - c. Developer shall provide two (2) copies of the following data for typical residences to be built in the subdivision and other loads such as pumping and lift stations:
    - 1) Size of units in square feet
    - 2) Major electrical appliances, HVAC systems, etc., and their ratings
    - 3) Service size proposed for each unit
    - 4) Calculated load on primary cable of any pumping or lift stations or other special facilities to be served from the electric system.

3. Providing the Department with copies of manufacturer's catalog cut sheets of all products proposed to be installed by the electrical Contractor for the electric power and street lighting facilities. Contractor shall submit two (2) copies of all equipment and material cut sheets to the Department for review and approval at least 4 weeks prior to the start of construction. Failure to complete the submittal and review process could result in the requirement of Contractor to replace unacceptable equipment or materials.
4. Planning the development, if possible, so that the primary system can be designed in a loop configuration to provide two sources of supply. In large developments or any other developments so designated by the Department, a loop system shall be mandatory. On a single feed system, it may be necessary to install duplicate cable to achieve a loop configuration. Plan the development so that the lots are developed consecutively. This will insure a continuous source of electric supply to all locations within the development.
5. Planning and installing other utilities so as not to interfere with the installation and operation of electric and street lighting cables, equipment and appurtenances and make arrangements for installation of these utilities prior to the electric installation.
6. Providing a project construction bond to GMLD for all electric and street lighting facilities in an amount not less than two (2) times the estimated electric and street lighting material costs for each phase of the subdivision project installed by the Developer or Contractor. Termination date on the bond(s) shall be one (1) year from energization of each phase of the subdivision project. Any waiver of this bonding requirement will be at the sole discretion of the GMLD.
7. Carrying out the following prior to the installation of the URD system:
  - a. Install surveyed lot corner bounds
  - b. Mark the points of curvature and tangency for all street front property line curves
  - c. Install curbs and bring sidewalks to subgrade
  - d. Install grade stakes showing final grade as requested at manholes, trench locations, transformers and secondary connection pedestals.
8. Notifying GMLD immediately of any lot line, project layout or other changes that could affect the electrical layout and sizing of project electrical and street lighting facilities
9. The supply and installation of all underground electrical facilities between GMLD's overhead riser pole(s) and the individual units or lots within the project.
10. The supply and installation of all underground street lighting facilities within the project.
11. The supply and installation of all sectionalizing facilities.
12. Reimbursement to the Department for the cost of Department furnished padmount transformers, street light poles and fixtures (including required spares), meter pedestals and any other material items furnished for the project. Any materials requested to be furnished by GMLD

will be ordered for the project only after receipt of a prepayment from the Developer for the materials. The Developer shall assume a minimum 16 weeks delivery time from date of receipt of prepayment to GMLD for padmount transformers.

13. The installation of all Department furnished padmount transformers, street light poles and fixtures.
14. The reimbursement to the Department for the cost of the "Department retained" engineering Consultant to design underground electric and street lighting facilities for the project.

Upon submittal of approved subdivision plans and other planning information, an estimate of the cost of the engineering services from the Department's engineering Consultant will be provided to the Developer or Contractor for budget purposes. The Department's Consultant is:

The Warner Consulting Group, Inc.  
P.O. Box 693  
Westborough, MA 01581  
(T) 508-842-4035  
(F) 508-845-9161

15. The reimbursement to the Department for the cost of interim and final inspections by Department staff or the Department's designated representative of the installation of electric and street lighting facilities. Prior to the initiation of construction, Contractor shall contact GMLD to develop an inspection plan for the project. Contractor is responsible for contacting the Department to conduct the following inspections:
  - a. All trenches shall be inspected prior to backfilling. Contractor will be required to completely expose any and all trenches not inspected by GMLD or its designated representative prior to backfilling. Exception: Trenches for secondary service laterals from the transformer or secondary connection pedestal shall be inspected by the Georgetown Wiring Inspector.
  - b. Testing and proving of conduits.
  - c. Installation of ground grids at all padmount transformer and sectionalizing cabinets.
  - d. Installation of primary power cable sections, as determined by the Department.
  - e. Installation of primary power elbow terminations, as determined by the Department.
  - f. Complete final inspection of all electrical and street lighting facilities. The electric and street light facilities must be inspected and approved by GMLD prior to any facilities being energized within a subdivision.

16. Attendance of Developer and electrical Contractor at a preconstruction meeting with Department representatives prior to the start of any work.
17. The reimbursement to the Department for the cost of the "Department retained" testing company to test the completed installation.
18. The supply and installation of the service lateral cable and conduit between all buildings and the Department's facilities (secondary connection pedestal or transformer) in accordance with the Georgetown Wire Inspector's requirements and specifications. The Department will make the final connections to its facilities.
19. The supply and installation of one or more Department furnished meter mount devices. These devices shall be located on a pedestal mount at approved locations for pedestal mounted meters.
20. Assumption of financial responsibility for:
  - a. Any discrepancy or change in final grade or plans which require an alteration of installed URD facilities.
  - b. Damage to the URD system during and after installation, caused by the Developer or Contractor and/or his agent or servants.
  - c. Replacement of any equipment or materials and any construction unacceptable to the Department.
21. Provide mylar reproducibles and CAD files of conformed-to-construction record drawings of Developer's subdivision plans based on Contractor's field markups of any project changes. These drawings and CAD files will be required to be furnished to the Department prior to energizing any services to homes.
22. Transfer of ownership of electric and street lighting facilities in the subdivision project to GMLD after completion of installation by the Contractor and testing and final acceptance by the Department. As part of the transfer of ownership, Developer shall also provide a summary of the cost of electric and street lighting facilities installed in the project, excluding costs for service laterals. If this cost information is not furnished, Developer will be charged the cost of engineering services for the Department's Consultant to estimate the cost of the installed facilities.
23. Any deviation from these "Instructions to Developers and Contractors for Underground Electrical Facilities for Subdivision Housing Projects" will be made only after submittal of a written request by Developer and receipt of written authorization by GMLD.

## Electric Department Responsibilities

The Department will perform the following at the expense of the Developer or Contractor:

1. Complete final design of electric power and street lighting facilities for the project, except secondary service laterals to the homes, based on Developer's approved subdivision plans.
2. Provide padmount transformers, street light poles and fixtures for installation by Contractor. Materials will be ordered for project only after receipt of prepayment from Developer.
3. Install riser pole(s) as required at the project extremities.
4. Conduct interim and final inspections of the Contractor's electric and street lighting facilities installation.
5. Test the completed underground facility prior to energization.
6. Make final connection of the streetlight and secondary cables at the padmount transformers and pedestal connection boxes.
7. Supply and install electric meters.
8. Supply and install materials for riser pole(s) except power cable and RGS conduit.
9. Make final interconnections between overhead facilities and primary cable terminations.
10. Own, operate, and maintain the underground distribution facilities, including primary and secondary systems, cables, sectionalizing facilities, transformers, secondary connection pedestals and streetlights but excluding meter pedestals secondary service laterals to the homes after facilities are transferred to the Department.

## **PART 2 - LAYOUT AND SIZING OF FACILITIES**

### **General**

This section provides general guidelines to the acceptable layout of underground electric and street lighting facilities within any new residential development.

### **Design of Electric and Street Light Facilities**

The Department's engineering Consultant will complete design of the primary and secondary electric systems and street lighting facilities based on the Developer's approved subdivision plans and the Department's guidelines for layout of electric facilities (design of the secondary service laterals is the responsibility of the electrical Contractor). Items requiring review and engineering work products by the Consultant shall generally include the following:

1. Review of Developer's approved subdivision plans and CAD drawing files.
2. Design of electric and street light facilities.
3. Preparation of a one-line diagram of electrical and street lighting facilities.
4. Addition of the approximate location of electric and street lighting facilities to Developer's subdivision plans.
5. Preparation of a major material requirements spreadsheet.
6. Sizing of cable and transformer facilities.
7. Review of field test-reports on completed installations.
8. Preparation of electric system conformed-to-construction record drawings based on Contractor's field markups of changes to electric and street lighting facilities on subdivision plans.

A copy of the drawings and major materials list prepared by the Department's Consultant will be provided to the Developer and GMLD for review and comment. After receipt of comments, a final set of P.E. sealed electric system design drawings will be provided to the Developer and GMLD.

### **Subdivision Drawings and Developer Load Data**

1. Two complete sets of Town approved subdivision drawings prepared by the Developer's civil engineer and illustrating the physical layout of all subdivision facilities shall be provided to the Department for review and use by the Department's Consultant. Physical drawings shall be to 1" - 40' scale and include topographic plans and indicate the layout of all lots, proposed location of all houses, driveways, septic systems, streets, sidewalks, above ground and buried drainage facilities, water, gas, telephone and cable utilities and facilities.
2. Developer shall also provide AutoCad files of all approved subdivision drawings and/or mylar reproducibles of each of the drawings.
3. Developer shall provide 2 copies of the following data for typical residences to be built in the subdivision and other loads such as pumping and lift stations:



- a. Size of units in square feet
- b. Major electrical appliances, HVAC systems, etc., and their ratings
- c. Service size proposed for each unit
- d. Calculated load on primary cable of any pumping or lift stations or other special facilities to be served from the electric system.

### **Distribution System Characteristics**

1. GMLD's distribution system is a four wire, grounded wye type consisting of 4.16 kV three-phase/2.4 kV single-phase lines and 13.8 kV three-phase/7.96 kV single-phase lines. Over time, the 4.16/2.4 kV distribution system facilities will be upgraded to 13.8 kV three-phase/7.96 kV single-phase operation.
2. All primary cable facilities and sectionalizing equipment provided by the Contractor shall be rated at 13.8 kV to accommodate future conversion to 13.8/7.96 kV operation, but sized to carry the higher load current for 4.16/2.4 kV operation if the electric facilities are initially operated at 4.16/2.4 kV.
3. The Department will furnish the padmount transformers at Developer's or Contractor's cost. Dual voltage padmount transformers will be provided if initial operation is at 4.16/2.4 kV.

### **Phase Selection**

In order to prevent significant load/voltage unbalances on the Department's system, the selection of the type of primary service (i.e., three-phase or single-phase) to each project shall be as follows:

1. A single-phase installation will be permitted where the maximum load current for the entire project (including all future phases) on the underground primary cable will not exceed the following:  

2.4 kV primary:	50 amperes
7.96 kV primary:	15 amperes
2. A three-phase installation is required where single-phase load current for the entire project is expected to exceed the values noted above.

## Guidelines For Facility Layout

### 1. Primary Cable/Conduit Layout

- a. In order to maintain reliability, the primary cable system shall be arranged for "looped" supply to all padmount transformers or sectionalizing cabinets. For projects with access to only one source of power, it may be necessary to install duplicate cable runs to achieve a looped supply.
- b. The looped supply shall normally be installed between two (2) independent feeder access points at physically separate riser poles at the project extremities. Where independent feeders are not available, install two risers on a common pole or risers on two adjacent riser poles.
- c. Conduits shall be installed between riser pole(s), padmount transformers and sectionalizing devices in such a manner to limit the cable "pulling" distance to a maximum of 500 feet. Sectionalizing cabinets shall be provided as required in the conduit system.
- d. For each active cable section, including the conduit to the riser pole(s), there shall be one spare conduit with pulling string installed in the unfilled conduit.
- e. Primary cable/conduit systems shall be located in the electric utility easement area off the roadway. Primary cable/conduit system road crossings shall be installed perpendicular to the roadway.
- f. Locate electrical conduits on opposite side of street from water mains and sidewalks.
- g. Locate conduits on "road side" of other utilities.

### 2. Secondary Cable/Conduit Layout

- a. Conduits shall be installed for secondary cable installations between padmount transformers and pedestal connection boxes.
- b. For each active secondary cable section there shall be one spare conduit with pulling string installed in the unfilled conduit.
- c. Secondary cable/conduit systems shall be located in the electric utility easement area off the roadway. Secondary cable/conduit system road crossings shall be installed perpendicular to the roadway.
- d. Locate conduits on "road side" of other utilities.

3. Service Lateral/Conduit Layout

- a. All service laterals shall be installed in Schedule 40 PVC conduit encased in a sand bed.
- b. All service laterals shall be connected at a pedestal connection box; or to a padmount transformer bushing, as determined by Department.
- c. Where customer meter pedestals will be located directly “across the road” from the transformer, GMLD may eliminate the requirement for secondary connection pedestals and permit wiring directly from transformer to meter pedestal.

4. Street Light Cable/Conduit Layout

- a. All street lights shall be connected through fuses at padmount transformers or secondary pedestal connection boxes.
- b. Street light cable/conduit systems shall be located in the electric utility easement area off the roadway. Street light cable/conduit system road crossings shall be installed perpendicular to the roadway.

5. Separation of Primary and Secondary Conduits From Other Utilities

- a. Horizontal Separation - maintain minimum of 12 inches horizontal separation from other utilities.
- b. Vertical Separation - maintain minimum of 12 inches vertical separation from other utilities at crossings.

6. Sectionalizing of Primary Circuit(s):

- a. On single-phase primary installations, sectionalizing will normally be performed at the dual bushing, feed through type padmount transformers. Single-phase sectionalizing cabinets shall be installed where intermediate sectionalizing facilities are required to limit primary cable pulling lengths to 500 feet.
- b. On three-phase primary installations, tapping of the primary underground cable loop for single-phase or three-phase padmount transformers or three-phase laterals shall be accomplished by means of three-phase sectionalizing cabinets and disconnectable cable elbow termination equipment facilities. Sectionalizing cabinets shall also be installed where intermediate sectionalizing facilities are required to limit primary cable pulling lengths to 500 feet.
- c. Each sectionalizing cabinet shall be located in an accessible location adjacent to access roads.

7. Padmount Transformers

- a. Each padmount transformer shall be located in an accessible location adjacent to access roads, on the opposite side of the access road from the sidewalk, if possible, and shall be arranged to supply as many individual homes as practical, with the length of secondary cable from the transformer to each meter pedestal being limited to approximately 200 feet. Any proposed installation that results in a secondary service exceeding 300 feet in total from the padmount transformer to the home will be reviewed by the Department for installation of a separate padmount transformer and/or by the Georgetown Wiring Inspector for an upgrade in secondary conductor size.
- b. All padmount transformers and secondary connection pedestals shall be located in the electric utility easement on the lot line between lots so that no service lateral crosses an adjacent property.
- c. All padmount transformers shall be mounted on box pad foundations.

8. Primary Cable Separable Terminators

All primary cable connections at all padmount transformers or sectionalizing cabinets shall be equipped with elbow type, loadbreak separable terminators.

9. Fault Indicators

All primary cable connections at all padmount transformers or sectionalizing cabinets shall be equipped with elbow or cable mounted fault indicators.

10. Secondary/Pedestal Connection Boxes:

- a. Secondary pedestal connection boxes shall be installed to provide a connection point between the padmount transformer and all service laterals. Install connection pedestals in the electric utility easement.
- b. Secondary pedestal connection boxes shall be installed when service is provided from a transformer located "across the road" from the service location. Such connection pedestals shall be located on lot lines, so that no service lateral will be located on any adjacent property.
- c. Where customer meter pedestals will be located directly "across the road" from the transformer, GMLD may eliminate the requirement for secondary connection pedestals and permit wiring directly from transformer to meter pedestal.

11. Metering Pedestals:

Metering pedestals shall be installed adjacent to the padmount transformer or pedestal connection box facing the street.

12. Lightning (Surge) Arresters:

- a. Lightning arresters shall be installed at all riser pole locations.
- b. Elbow type surge arresters shall be installed at sectionalizing cabinets and padmount transformers with unused primary bushings as required by the Department. Typical locations are at the end of radial circuit, at both ends of an open point on a loop system, or at intermediate locations where protection is required.

13. Streetlights:

Streetlights shall be located within each project as follows:

- a. At the intersection of the subdivision road with the town road.
- b. At all road intersections within the subdivision.
- c. At additional locations deemed necessary by the Department.
- d. Between sidewalk and curb.

## Sizing of Electrical Facilities

### 1. General:

The Contractor shall be responsible for the sizing of all service laterals within the project in accordance with the Georgetown Wire Inspector's requirements and specifications. Such sizing shall be based upon load calculations developed by the Contractor which will appropriately reflect anticipated load levels within each home of the subdivision.

### 2. Sizing Criteria:

#### a. Primary Cables:

Primary cables shall be sized to meet the anticipated coincident peak load of the project as if the entire project was being supplied from a single source (i.e. not being loop fed). One size primary cable shall be utilized throughout the entire project. Minimum primary cable conductor size shall be #1/0 AWG aluminum.

#### b. Secondary Cables:

Secondary cables from transformer to pedestal connection boxes and from pedestal connection boxes to pedestal connection boxes shall be a minimum of 350 kcmil conductor, with XHHW or equivalent insulation.

#### c. Street Light Cables

Street light cables shall be sized at not less than 2 -#12 AWG minimum copper conductor with ground conductor. Larger cable sizes may be required for long cable runs.

#### d. Padmount Transformers:

Transformers shall be sized to meet the ultimate coincident peak load estimated to exist at the individual transformer location.

#### e. Riser Pole Fuses:

Riser pole fuses shall be sized to meet the anticipated coincident peak load of the project as if the entire project was being supplied from a single source (i.e. not being loop fed).

#### f. Conduit

Conduit shall be sized per the National Electric Code with minimum sizes as follows:

1. Primary Conduit - 4 inch diameter
2. Secondary Conduit - 4 inch diameter
3. Streetlight Conduit - 2 inch diameter

## **PART 3 - EQUIPMENT SPECIFICATIONS**

### **General:**

1. This section specifies the equipment facilities required for underground projects on the Department's system. Unless otherwise identified, all electrical equipment provided herein shall conform to the current rules, regulations and specifications of one or more of the following authorities:

American National Standards Institute (ANSI)  
American Society for Testing and Materials (ASTM)  
Edison Electric Institute (EEI)  
Institute of Electrical & Electronic Engineers (IEEE)  
Insulated Cable Engineers Association (ICEA)  
National Electrical Code (NEC)  
National Electrical Manufacturers Association (NEMA)  
National Electrical Safety Code (NESC)  
Underwriters Laboratories, Inc. (UL)

2. The above listed codes and standards are referenced to establish minimum requirements and wherever these specifications require higher grade of materials or workmanship than required by the codes and standards, these specifications shall apply. In the event a conflict occurs between the above listed codes and standards and these specifications the more stringent requirement shall govern.

### **Materials and Workmanship:**

1. All equipment, materials and products shall be new, of high quality and of "utility grade", free from defects and imperfections, of recent manufacture and of the classification and grades designated. All materials, supplies and articles shall be products of recognized reputable manufacturers.
2. All workmanship shall be of the highest grade and in accordance with the modern standard practice.

### **Primary Cable**

All primary power cable shall be chemical and moisture resistant, single-phase, jacketed, concentric-neutral, 15 kV class, underground primary distribution cable.

1. Voltage Rating: 15 kV, 133% insulation level.
2. Conductors: Aluminum, hard drawn with Class B stranding, #1/0 AWG minimum conductor size.

### **Fault Indicators**

1. Where fault indicators are required on the underground cable system, they shall be elbow mounted or cable type, auto reset on load current, with minimum operating trip level of 200 amperes.
2. Manufacturer: Cooper Power Systems type S.T.A.R. TPR FCI variable trip test point reset (catalog #STV) and S.T.A.R. 6' fiberoptic cable assembly (catalog #SFOC).

### **PVC Conduit and Accessories for Electrical Conduits**

1. Furnish Schedule 40 PVC and Schedule 80 PVC conduit.
2. Furnish conduit straight and true in minimum 10 foot lengths.
3. Furnish conduit system with couplings, adaptors, sweeps, spacers, supports and all other accessories as required for a complete installation.
4. Furnish material and accessories supplied by the same manufacturer.
5. Furnish PVC conduits and fittings that are homogeneous plastic material free from cracks, holes or foreign inclusions with a conduit bore smooth and free of blisters, nicks or other imperfections which could damage the cables.
6. Fittings: Self-sealing type or sealed with conduit manufacturer's approved sealing compound.
7. Spacers: Non-metallic interlocking type.
8. End Caps: Provided with pull tabs.
9. Minimum Conduit Sizes
  - A. Primary Conduit - 4 inch diameter
  - B. Secondary Conduit - 4 inch diameter
  - C. Streetlight Conduit - 2 inch diameter
10. Manufacturers: Carlon, Condux or GMLD approved manufacturer.

### **RGS Conduit at Riser Pole and Box Pad Installations**

Conduit for riser pole and box pad installations shall be rigid steel conduit (RGS), zinc coated in accordance with ANSI C80.1 and UL6.



4. Marking: cable identification as directed by Department.
5. Manufacturers: GMLD approved manufacturer.

### **Conduit Pulling Line**

1. Type: 3/16 inch polyethylene or polyolefin line
2. Rating: 500 pounds
3. Manufacturer: Greenlee, Gardner-Bender or GMLD approved manufacturer.

### **Primary Cable Elbow Terminations and Accessories**

1. Cable elbow type separable connectors shall be supplied at all cable terminations at padmount transformers and sectionalizing cabinets.
2. The elbows shall be 200 A loadbreak type, matched to the bushing and junctions provided on the padmount transformers and sectionalizing cabinets and shall be rated 15 kV with electrical and mechanical characteristics per ANSI/IEEE Standard 386.
3. All elbows shall be furnished with bail and capacitive test points.
4. Furnish insulated protective caps with ground for all unused bushing junctions at padmount transformers and sectionalizing cabinets.
5. All elbow/cable interfaces shall be covered with an additional cold shrink sleeve.
6. Elbow Manufacturers: Elastimold, Cooper Power Systems or GMLD approved manufacturer.
7. Sleeve Manufacturers: 3M or GMLD approved manufacturer.

### **Primary Separable Connector Surge Arresters**

1. The elbow surge arresters shall be 200 A loadbreak type, matched to the bushings and junctions provided on the padmount transformers and sectionalizing cabinets with electrical and mechanical characteristics per ANSI/IEEE Standard 386. Elbow surge arresters shall be rated for 15 kV systems, with the following characteristics:

Type:	Elbow
Duty Cycle Voltage:	12 kV
MCOV Voltage Rating:	10.2 kV

2. Manufacturers: Elastimold, Cooper Power systems, Joslyn, or GMLD approved manufacturer.

3. Strand Shielding: extruded semiconducting layer of tree retardant cross-linked polyethylene, or ethylene propylene rubber with an average thickness of not less than 15 mils. The strand shielding shall be the insulation.
4. Insulation: tree retardant cross-linked polyethylene or ethylene propylene rubber providing a 133% insulation level; minimum average wall thickness of 220 mils; and rated 90°C continuous, 130°C emergency, and 250°C short circuit.
5. Insulation Shield: extruded semi-conducting crossed linked shield with a maximum resistivity of 5000 ohms-cm. with minimum average thickness not less than 30 mils.
6. Concentric Neutral: bare copper wire # 14 or larger served with a lay of 6 - 10 times the cable diameter. The number and size of concentric neutral conductors cable shall be rated to provide 100 percent of the current carrying capacity of the primary conductor.
7. Jacketing: linear, low density polyethylene jacket. Jacket shall embed and cover the neutral wires with a minimum average thickness of 50 mils over the neutral wires.
8. Identification: marked at intervals of no more than 36 inches to show manufacturer's name, year of manufacture, conductor size, voltage class, type and thickness of insulation, and type and thickness of jacket.
9. Testing: All cables shall be tested in accordance with the latest requirements of ICEA and AEIC CS5 Standards.
10. Manufacturers: Okonite, Pirelli, Hendrix or GMLD approved manufacturer.

### **Cable Pulling Lubricant**

Furnish cable lubricant which is identified by cable manufacturer as compatible with cable jacket material and PVC conduit.

### **Cable Identification Tags**

1. Type: Horizontal reading, strapped to cables with mylar self-locking tags at each end of holder.
2. Tags: polyethylene with black 1-inch high characters on yellow background.
3. Holders: black polyethylene.

## Padmount Transformers

Padmount transformers with the following characteristics will be furnished by the Department. Padmount transformers shall be mounted on Contractor furnished box pads.

### 1. Principal Ratings:

Dual Voltage Rating:	2.4 x 7.96 kV
Single Voltage Rating:	7.96 kV
Secondary Voltage Rating:	120/240 V
BIL Rating:	60 x 95 or 95 kV
Impedances:	Manufacturer Standard
Temperature Rise:	65 degree C
Frequency:	60 Hz
Bushing arrangement:	Loop Feed

### 2. General Construction Features:

- a. Constructed in accordance with ANSI C57 and NEMA standards.
- b. Compartmental type, self-cooled, tamper resistant and weather protected for mounting on a pad with no exposed screws, bolts or other fastening devices which are externally removable.
- c. High and low voltage compartments will be located side by side. Terminal compartments will be full height, air filled with individual doors capable of being padlocked in the closed position. Doors will be equipped with lift-off type steel hinges and secure door stops to hold the doors open while working in the compartment.
- h. Front sill of the compartment will be removable to allow the transformer to be rolled or skidded into position over conduit studs. ANSI tank grounding provisions will be furnished in each compartment.

### 3. High Voltage Terminations:

The high voltage terminations will be dead-front arranged for loop feed and provided with one piece load break integrated bushings for use with 200 A loadbreak elbow terminators. One (1) parking stand will be provided.

### 4. High Voltage Protection:

Primary protection will be provided by Bay-O Net type oil immersed fuses with a minimum fault interrupting rating of 5,000 amperes symmetrical. Fuse(s) will be externally replaceable with a distribution hot stick without opening the transformer tank.

5. Low Voltage Terminations:

Low voltage bushing will be molded epoxy and provided with threaded stud for 6 lug secondary terminal bar with cover. The low voltage neutral will be an insulated bushing grounded to the transformer tank by a removable grounding strap. The primary and secondary neutrals will be internally tied with a removable link for testing.

**Sectionalizing Cabinets**

1. Where sectionalizing cabinets are required they shall be above ground type, consisting of a metal enclosure with internally mounted load break junctions and parking stands as required. Sectionalizing cabinets shall be mounted on box pads.

2. Ratings: The equipment shall have the following minimum ratings:

Nominal Voltage Rating:	15 kV
BIL Rating:	95 kV
Continuous Current Rating:	200 A

3. Cabinet and Framework:

- a. Outdoor, weatherproof type, metal enclosed. The units shall have suitable framework to provide a self-supporting rigid and stable structure. The enclosure and framework of the structure shall be sufficiently rigid to support all facilities without vibration. The exposed exterior surface shall not be drilled or welded for the purpose of attaching wires or switchgear devices if such holes or fastenings will be visible after installation.
- b. Metal enclosures shall consist of selected sheets of smooth sheet steel. Sheet steel shall not be less than No. 11 U.S. Standard Gauge, forming structural shapes or having bent angle or channel edges, with all corner seams welded and ground smooth.
- c. Each cabinet shall be equipped with a minimum of two (2) parking stands per phase for cable accessories.
- d. The exposed surfaces of metal cabinets shall be thoroughly cleaned after fabrication by sandblasting, picking and rinsing or by other approved means. The cleaning process shall be followed immediately by application of a rust-inhibitive wash process (bonderizing or approved equal). All outside panel surfaces shall then be primed, filled where necessary, and given no less than two (2) coats of synthetic undercoat. The finish coat shall be a semi-gloss paint.
- e. The cabinets shall be supplied with hinged door(s) easily operable by one person. The door shall be padlockable in the closed position and be provided with secure stops in the open position to prevent accidental and/or unexpected closing of door. Cabinet shall be bolted to pad.

4. Junctions:
  - a. Sectionalizing cabinets shall be furnished with factory installed universal junction mounting plates and two-way, three-way or four-way junctions in single-phase or three-phase configurations as required at the individual cabinet locations.
  - b. Junctions shall be one piece loadbreak integrated bushings for use with 200 A loadbreak elbow terminators and shall be rated 15 kV with electrical and mechanical characteristics per ANSI/IEEE Standard 386.

5. Grounding:

Grounding facilities will be provided within each termination cabinet to facilitate the interconnection of #2/0-#4/0 AWG ground cable and grounding of power cable ground shields/conductors.

6. Color: Willow Green

7. Manufacturers: Cooper Power Systems(SecTER) or GMLD approved manufacturer.

**Padmount Transformer and Sectionalizing Cabinet Operating Numbers**

1. Type: reflective, self-adhesive, 2 inch high white on black or yellow on black.

**Sectionalizing Cabinet Danger Signs**

1. Type: reflective, self-adhesive, similar to the NEMA warning labels furnished on padmount transformers.
2. Manufacturer: WR Frick, American Safety Utility Co, Electromark or GMLD approved manufacturer.

**Box Pads**

1. Box pads shall be provided for all padmount transformers and sectionalizing cabinets.
2. Contractor shall coordinate size of box pads with dimensions of Department furnished padmount transformers and Contractor furnished sectionalizing cabinets.
3. Box pads shall be of heavy duty, reinforced fiberglass construction.
4. Color: Willow Green
5. Manufacturers: Nordic Fiberglass or GMLD approved manufacturer.

### **Secondary Connection Pedestals**

1. Secondary connection pedestals may be installed as an alternative to secondary handholes per GMLD approval.
2. Pedestals shall be heavy duty, reinforced fiberglass or high-density polyethylene construction, with minimum 12"x19" top dimension, 18"x18" base opening, 26.5"x26.5" bottom opening and 30" overall height.
3. Color: Willow Green
4. Manufacturers: Nordic Fiberglass Model PSP-151530 or GMLD approved manufacturer.

### **Secondary Meter Pedestals**

1. Meter pedestals shall be steel type construction.
2. Manufacturers: Anchor Electric, Milbank or GMLD approved manufacturer.

### **Street Lights**

Street lights and fixtures with the following characteristics will be furnished by the Department.

1. Street light fixtures: McGraw Edison catalogue No. TR 1381 (no substitute) for 120 volt operation with black finish, supplied complete with photocontrol receptacle and polycarbon reflector panels, 70 watt HPS bulb and photocell, clear lens.
2. Street light posts: Hadco model No. P1300 with round post subbase #01701123A, no substitute.
3. GMLD will also furnish a minimum of two (2) complete spare street light installations including poles, fixtures and subbases plus 20 percent additional spares for projects with more than 10 streetlights.

### **Secondary Cable**

1. Type: single conductor
2. Voltage: 600V
3. Conductor: 350 kcmil copper, 37 strand
4. Insulation: 65 - 95 mils, 90°C, rated for wet locations, NEC type XHHW-2 or RHW-2.

### Street Light Cable

1. Type: NEC UF, 2-conductor with ground wire
2. Voltage: 600V
3. Conductor: #12 AWG copper
5. Ground Wire: #12 AWG copper
6. Insulation: 19 mils PVC with nylon jacket
7. Overall Jacket: PVC, sunlight resistant

## **PART 4 - INSTALLATION SPECIFICATIONS**

### **General:**

1. This section identifies the installation specifications for the underground electric and street light system and components provided by the Contractor. Unless otherwise identified, all electrical equipment and facilities installation shall conform to the current rules, regulations and specifications of one or more of the following authorities:

American Concrete Institute (ACI)  
American National Standards Institute (ANSI)  
American Society for Testing and Materials (ASTM)  
Edison Electric Institute (EEI)  
Institute of Electrical and Electronic Engineers (IEEE)  
Insulated Cable Engineers Association (ICEA)  
National Electrical Code (NEC)  
National Electrical Manufacturers Association (NEMA)  
National Electrical Safety Code (NESC)  
Underwriters Laboratories, Inc. (UL)  
Occupational Safety and Health Administration (OSHA)  
Commonwealth of Massachusetts State Electrical Code  
Any applicable federal, state and local codes and regulations

2. The above listed codes and standards are referenced to establish minimum requirements and wherever these specifications require higher grade of materials or workmanship than required by the codes and standards these specifications shall apply. In the event that a conflict occurs between the above listed codes and standards and these specifications, the more stringent requirement shall govern.
3. All construction services shall be in accordance with good construction practice, these technical and performance requirements, generally accepted electric utility practices, and applicable federal, state and local laws, codes and regulations.
4. All primary and secondary work shall be completed by an electrical Contractor properly licensed in the Commonwealth of Massachusetts.

### **Workmanship:**

All work shall be done in an orderly and workmanlike manner and shall present a neat appearance when completed.

### **Preconstruction Meeting:**

Developer and electrical Contractor shall attend a preconstruction meeting with Department representatives prior to the start of any work. Topics covered at the meeting will include:



1. Designate personnel representing each party, including the address for sending official correspondence and the address and telephone number of Developer's and Contractor's representatives who will be Project Managers and responsible and available outside of normal working hours for emergency repairs and maintenance of safety devices.
2. Review construction schedule and required Department inspections and inspection notification requirements.
3. Review status of Contractor's submittal of copies of manufacturer's catalog cut sheets of all products proposed to be installed by the electrical Contractor for the electric power and street lighting facilities.
4. Other matters relevant to the project.

If the Developer changes electrical Contractor, the new electrical Contractor shall attend a preconstruction meeting with Department representatives prior to the start of any work by the new Contractor.

**Inspections:**

All work performed by electrical Contractor shall be periodically inspected by the Department. Contractor shall contact GMLD to develop an inspection plan for the project prior to the initiation of construction. Contractor is responsible for contacting the Department to conduct the following inspections:

1. All trenches shall be inspected prior to backfilling. Contractor will be required to completely expose any and all trenches not inspected by GMLD or its designated representative prior to backfilling. Exception: Trenches for secondary service laterals from the transformer or secondary connection pedestal to the home shall be inspected by the Georgetown Wiring Inspector.
2. Testing and proving of conduits.
3. Installation of ground grids at all padmount transformer and sectionalizing cabinets.
4. Installation of primary power cable sections, as determined by the Department.
5. Megger testing of power cable.
6. Installation of primary power cable elbow terminations, as determined by the Department.
7. Complete final inspection of all electrical and street lighting facilities. The electric and street light facilities must be inspected and approved by GMLD prior to any facilities being energized within a subdivision.

### Underground Conduit System:

1. Conduit shall be installed as shown on installation Detail Sheet Nos.DM-5, DM-6 and DM-6A in PART 5.
2. Install conduits on "road side" of other utilities.
3. Separation of Primary and Secondary Conduits From Other Utilities
  - a. Horizontal Separation - maintain minimum of 12 inches horizontal separation from other utilities.
  - b. Vertical Separation - maintain minimum of 12 inches vertical separation from other utilities at crossings.
4. Conduit shall be schedule 40 PVC, minimum size four inches (4') for primary circuits, four inches (4") for secondary circuits and two inches (2") for streetlight circuits.
5. Conduit at riser poles shall be rigid galvanized steel.
6. Install 90 degree RGS conduit sweeps with a 36-inch minimum radius on each conduit at riser poles
7. Install 4-inch RGS conduit on each riser pole to a minimum of 10 feet above grade and a minimum of 10 feet below grade from RGS conduit sweep, per installation Detail Sheet No. DM-1 in PART 5.
8. Where, due to ledge or other problems, the specified depth of burial for primary or secondary conduit is unable to be obtained, the Contractor shall utilize galvanized steel conduit (RGS) or Schedule 80 PVC conduit. In such cases, the conduit shall be installed to a minimum depth of 24" and shall be encased in sand.
9. In all cases, the entire conduit system shall have Caution Tape placed 12 inches above the conduit.
10. Requirements for the installation of primary conduits is summarized in the following table and on Detail Sheet No. DM-4 in PART 5.

<b>Primary Voltage Conduit System</b>			
<b>Feature</b>	<b>Normal Installation</b>	<b>Shallow Installation &amp; Roadways &amp; Driveways</b>	
<b>Conduit Type</b>	Sch 40 PVC	Sch 80 PVC	RGS
<b>Minimum Conduit Size</b>	4"	4"	4"
<b>Minimum Conduit Sweep</b>	24"	24"	24"
<b>Embedment Type</b>	Sand	Sand	Sand
<b>Minimum Burial Depth</b>	48"	24"	24"

11. Requirements for the installation of secondary conduits is summarized in the following table and on Detail Sheet No. DM-5 in PART 5.

<b>Secondary Voltage Conduit System</b>			
<b>Feature</b>	<b>Normal Installation</b>	<b>Shallow Installation &amp; Roadways &amp; Driveways</b>	
<b>Conduit Type</b>	Sch 40 PVC	Sch 80 PVC	RGS
<b>Minimum Conduit Size</b>	4"	4"	4"
<b>Minimum Conduit Sweep</b>	16"	16"	16"
<b>Embedment Type</b>	Sand	Sand	Sand
<b>Minimum Burial Depth</b>	36"	24"	24"

12. Requirements for the installation of street lighting conduits is summarized in the following table.

<b>Street Light Conduit System</b>		
<b>Feature</b>	<b>Normal Installation</b>	<b>Shallow Installation &amp; Roadways &amp; Driveways</b>
<b>Conduit Type</b>	Sch 40 PVC	Sch 80 PVC
<b>Minimum Conduit Size</b>	2"	2"
<b>Minimum Conduit Sweep</b>	18"	18"
<b>Embedment Type</b>	Sand	Sand
<b>Minimum Burial Depth</b>	24"	24"

13. Trench Excavation and Backfill

- a. Excavate trench to dimensions, lines and grades as shown installation Detail Sheet Nos. DM-4 and DM-5 in PART 5.
- b. Stockpile excavated material suitable for use as backfill.
- c. Remove unstable and unsatisfactory materials from the bottom of the excavation.
- d. Backfill over-excavated areas with suitable backfill materials generated in the work and approved by GMLD or suitable imported backfill materials.
- e. Ensure excavations are kept dry and free of standing water.
- f. Maintain side slopes of excavations in accordance with OSHA guidelines. Furnish and install shoring and bracing conforming to OSHA guidelines where conditions require it.
- g. Ensure trench bottom soil is at optimum moisture content. Add water or allow soil to dry as needed.
- h. Proof compact trench bottom by making 2 passes with a vibratory plate compactor prior to installation of conduits.
- i. Ensure conduit installation is complete and inspected and approved by GMLD prior to initiating backfilling operations.
- j. Do not backfill over, wet, frozen or unstable subgrade surfaces.
- k. Maintain optimum moisture content of backfill materials to attain required compaction density.

14. Sand Encased Conduits

- a. Encase conduits as shown on installation Detail Sheet Nos. DM-4 and DM-5 in PART 5.
- b. Inspect all conduits before installation to ensure they are free from cracks, holes or foreign inclusions. Ensure the conduit bore is smooth and free of blisters, knicks, or other imperfections which could damage conductors or cables.
- c. Install conduits in not less than 10-foot minimum lengths, except at the end of a run or at bends.

- d. Make all field cuts of PVC conduit with a hacksaw. Make the cut square to the conduit axis. Ream the cut end smooth. Join field cut conduits with couplings designed for this purpose.
- e. Join all PVC conduits and fittings with a solvent cement in strict accordance with the manufacturers' recommendations or utilize self-sealing fittings.
- f. Make all field cuts of rigid galvanized steel conduit (RGS) with a device that will not damage the conduit. Ream all field cut ends to remove burrs and rough edges. Utilize unions to join lengths of RGS conduit where it is inconvenient to use standard couplings. Expansion couplings that expand the conduit diameter are prohibited from use.
- g. Install all conduits between riser pole and terminal box pads, between box pads or from box pads to secondary connection pedestals with a minimum slope of 2 inches per 100 feet or with a high point and a minimum slope of 2 inches per 100 feet.
- h. Maintain continuous earth support under conduits and make transitions in as straight an alignment as possible when changes in the formation of conduits in a duct run are necessary.
- i. Direct Buried Conduits
  - 1) Prepare trenches as described above.
  - 2) Install direct buried conduits at a depth that will result in a minimum of 24 inches of native backfill cover over the sand backfill material.
  - 3) Place 3 inches compacted sand backfill under, and around and over direct buried conduits.
  - 4) Exercise extreme care in the placement of sand backfill around conduits to prevent foreign matter, dirt and concrete from entering conduits at couplings and terminations.
  - 5) Backfill above sand with native backfill.
- j. Plug the ends of all conduits at the end of each work day or when conditions require it to prevent water and debris from entering the conduits.
- k. Pull a standard flexible mandrel, not less than 12 inches long and having a diameter approximately 1/4 inch less than the inside diameter of the conduit, through each completed conduit. Replace all conduits that do not allow passage of the mandrel.
- l. Pull a stiff bristle brush through each completed conduit after the mandrel operation is

complete to ensure that no particles of earth, sand, gravel or other foreign material has been left in the conduit.

- m. Terminate RGS conduits in box pads with RGS bushing terminations.
- n. Plug both ends of all conduit runs with plastic inserts equipped with pull tabs.
- o. Install a 3/16 inch, 500 lb. polypropylene or polyolefin rope or GMLD approved equal in each length of completed conduit and tie to the pull tab provided on the conduit plugs.

### **Primary and Secondary Cable**

1. Primary and secondary cables shall be installed after the completion and cleaning of the conduit system.
2. All primary cables shall be tagged for their destination, i.e., from pole to padmount or padmount to padmount, sectionalizing cabinet to sectionalizing cabinet, etc., at each end with Department approved cable tags. Contractor shall use designations specified by the Department, including phase identification.
3. The Contractor shall pull primary and secondary cable into the conduit system with sufficient length to provide at least one full loop around interior of box pads and secondary connection pedestals and conveniently make the connections to all equipment.
4. The minimum radius to which an insulated conductor shall be bent shall be 10 times the diameter over the outer covering for rubber and thermoplastic insulated cables and 12 times the outer diameter for the primary shielded cables.
5. Where a lubricant is utilized as an aid in pulling cable, a nonconducting lubricant or cable pulling compound that is not injurious to the jacket or insulation shall be used. The use of oil or grease is not permitted. Excessive pulling stresses shall be avoided.
6. All primary and secondary cable runs shall be continuous, with no splices permitted.
7. Cables damaged during installation shall be removed and replaced by Contractor at the Contractors expense.
8. Leave sufficient "spare" cable below transformer or sectionalizing cabinet to provide at least one full loop around interior of box pads and facilitate replacement of elbow termination if necessary.
9. Install elbows terminators on primary cable at padmount transformers and sectionalizing cabinets in accordance with manufacturers instructions.

10. Install cables in accordance with ANSI and IEEE C2.
  - a. Do not exceed cable pulling tensions and bending radius at any time during handling or installation.
  - b. Pull cable using suitable lubricants and cable pulling equipment. Ensure cable is well lubricated before being pulled into conduits. Locate reels conveniently for feeding cable into the conduit without causing excessive bending or possible injury to cable by abrasion.
  - c. Pull cable using pulling eyes in accordance with manufacturer's recommendations except as otherwise specified. Pull cables with gradual and uniform tension utilizing a dynamometer. Attach lines to cables with ball bearing swivels to prevent twisting of cable during pulling. Submit report of maximum pulling tension recorded for each cable for each section to GMLD.
  - d. Furnish a measuring device that will continuously indicate the length of cable pulled. Include this information on the cable pulling report.
  - e. Seal cable ends when pulling into conduit. Do not leave cable ends exposed to moisture unless splicing is to be done immediately.
  - f. Station sufficient personnel along the cable route at all conduit entrances and exits to direct the passage of cable as required.
  - g. Protect the cable from chafing on the ground, conduit edges or other sharp surfaces during pulling. Provide timbers and flexible cable pulling tubes to guide and protect the cable.
  - h. Clamp or snub each cable and tie for proper support at each terminal connection so that strain on the cable is not transmitted to the terminal connection.
11. Perform cable phase identification and phasing tests before initiation of termination activities at padmount transformers and sectionalizing cabinets. Perform "megger" insulation resistance test on each cable to ground prior to terminating. Record temperature, humidity, duration of test and voltage for each test and submit to GMLD.
12. Replace with new cable if required insulation resistance cannot be obtained.
13. Complete installation of elbow terminations in accordance with manufacturer's instructions. Install additional cold-shrink sleeve at cable/elbow interface.
14. Ground cable sheaths at each padmount transformer and sectionalizing cabinet to perimeter grounding conductor with 2/0 AWG copper conductor.

## 15. Cable Identification

- a. Mark all cables with cable circuit and phase identification tags, where applicable.
- b. Securely fasten cable identification tags to cables at each end of tag holder with self-locking nylon ties, in visible locations at each termination and in each manhole. Coordinate the numbering system with GMLD.

### **Box Pads**

1. Install box pads as shown on installation Detail Sheet Nos. DM-2, DM-2A, DM-3 and DM-3A in PART 5.
2. Prepare for installation of box pads by overexcavating at least 6 inches deeper than depth of box pads.
3. Stockpile excavated material suitable for use as backfill.
4. Remove unstable and unsatisfactory materials from the bottom of the excavation.
5. Install and compact a minimum of 12 inches of crushed rock or sand in bottom of excavation for drainage purposes.
6. Install box pad per manufacturers instructions.
7. Ensure conduits are properly exposed and terminated with end bells and box pad installation is complete prior to initiating backfilling operations. Fill area inside box pad with sand to a level below top of exposed conduits.
8. Backfill over-excavated areas with suitable backfill materials generated in the work and approved by GMLD or suitable imported backfill materials.

### **Padmount Transformers**

1. Install all padmount transformers as shown on installation Detail Sheet Nos. DM-3 and DM-3A in PART 5. Leave sufficient "spare" cable below transformer to provide at least one full loop around interior of box pads and facilitate replacement of elbow termination if necessary.
2. Install ground grid around transformer bank as shown. Install ground cable into high and low voltage transformer compartments and interconnect to primary and secondary cable neutrals and transformer tank ground.
3. Grade property adjacent to transformer location to permit access to transformer compartments and operation of cable elbow termination with hot-sticks.



### **Sectionalizing Cabinets**

1. Install all sectionalizing cabinets as shown on installation Detail Sheet Nos. DM-2 and DM-2A in PART 5.
2. Install ground grid around sectionalizing cabinet as shown. Install ground cable into sectionalizing cabinet and interconnect to cabinet ground connector and primary cable neutrals.
3. Grade property adjacent to sectionalizing cabinet locations to permit access and operation of cable elbow terminations with hot-sticks.

### **Cabinet Operating Numbers**

1. Mark all padmount transformers and sectionalizing cabinets with self-adhesive identification tags.
2. Coordinate the numbering system with GMLD.

### **Sectionalizing Cabinet Warning Signs**

1. Attach warning signs to front of sectionalizing cabinets.

### **Secondary Connection Pedestals**

1. Prepare for installation of pedestals by overexcavating at least 6 inches deeper than depth of pedestal.
2. Stockpile excavated material suitable for use as backfill.
3. Remove unstable and unsatisfactory materials from the bottom of the excavation.
4. Install and compact a minimum of 12 inches of crushed rock or sand in bottom of excavation for drainage purposes.
5. Install pedestal per manufacturers instructions.
6. Ensure conduits are properly exposed and pedestal installation is complete prior to initiating backfilling operations. Fill area inside pedestal with sand to a level below top of exposed conduits.
7. Backfill over-excavated areas with suitable backfill materials generated in the work and approved by GMLD or suitable imported backfill materials.

### Meter Pedestals

1. Install meter pedestals in 18" of concrete.
2. Install meter pedestals so meter faces street.

### Street Lights

1. Install street light bases, lights and fixtures in accordance with manufacturer's instructions.
2. Electric supply to individual street light shall be directly from the closest padmount transformer or secondary connection box or connection pedestal.
3. All street lights shall be connected through fuses located at padmount transformers or pedestal connection boxes.
4. Furnish GMLD with a minimum of two (2) complete spare street light installations including poles, fixtures and subbases.

### Testing

1. Upon completion of the underground construction, the Contractor shall advise the Department that the facility is ready for final inspection and/or testing.
2. The Department shall arrange for electrical testing of the completed facility. The cost of such testing shall be reimbursed to the Department by the Contractor as previously indicated.
3. Any equipment or facilities that fail to pass the testing shall be removed and replaced at the Contractor's expense. The cost for retesting such equipment after replacement shall also be the responsibility of the Contractor.
4. After satisfactory testing of the completed installation and submittal of final conformed-to-construction record drawings and CAD files, and payment of any outstanding amounts to the Department, the facilities will be energized by the Department and electric service to the project will commence.

## PART 5 - INSTALLATION DETAIL SKETCHES

The following sketches are attached to illustrate typical installation details and requirements:

<u>Detail No.</u>	<u>Detail Title</u>
DM-1	Riser Pole Conduit Installation
DM-2	Sectionalizing Cabinet Detail (Standard Conduit Depth)
DM-2A	Sectionalizing Cabinet Detail (Shallow Conduit Depth)
DM-3	Pad Mounted Transformer Detail (Standard Conduit Depth)
DM-3A	Pad Mounted Transformer Detail (Shallow Conduit Depth)
DM-4	Primary Underground Conduit Detail
DM-5	Secondary Underground Conduit Detail
DM-6	Padmount Equipment Easement Requirements (Largest Padmount Installation)

ITEM	MATERIAL
1	4" DIA. RGS CONDUIT 10' LENGTH
2	4" DIA. GALV. STEEL SWEEP 36" RADIUS
3	4" DIA. STEEL COUPLING
4	NOT USED
5	4" GALV. STEEL STRAP
6	NOT USED
7	4" SCH 40 PVC CONDUIT

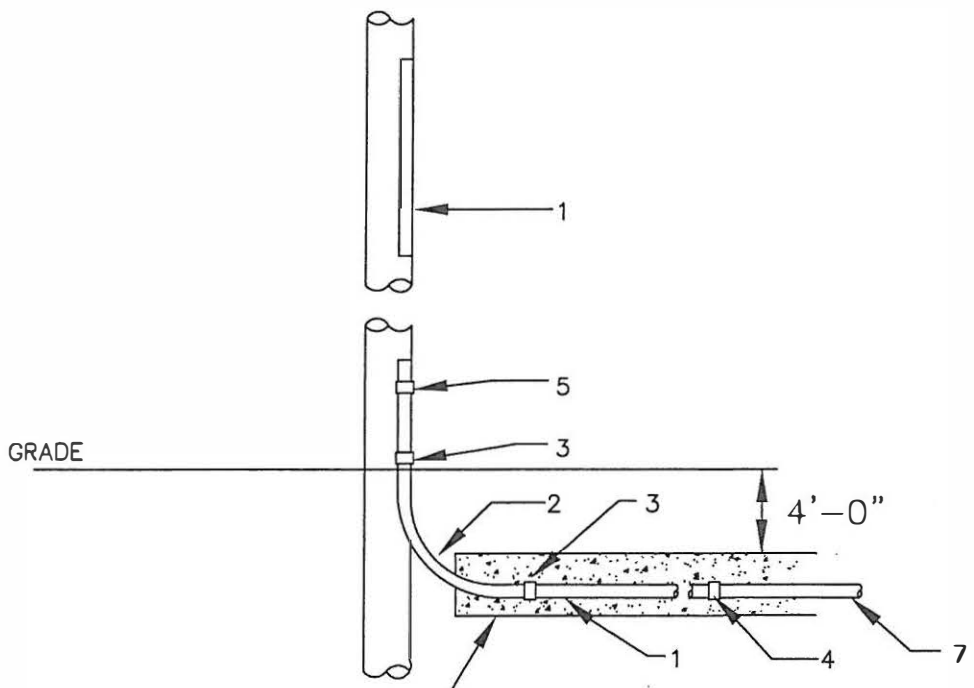

SAND ENCASED  
SEE DETAIL DM-4.

NOTE:  
STUB AND CAP SPARE  
CONDUIT 8" ABOVE GRADE.

URD GMLD  
STANDARDS

DES GW  
DWN DMM  
CK'D GW

RISER POLE CONDUIT  
INSTALLATION

DATE: 2/28/00  
SCALE: NONE  
DWG NO. DM-1  
FILE: DM-1

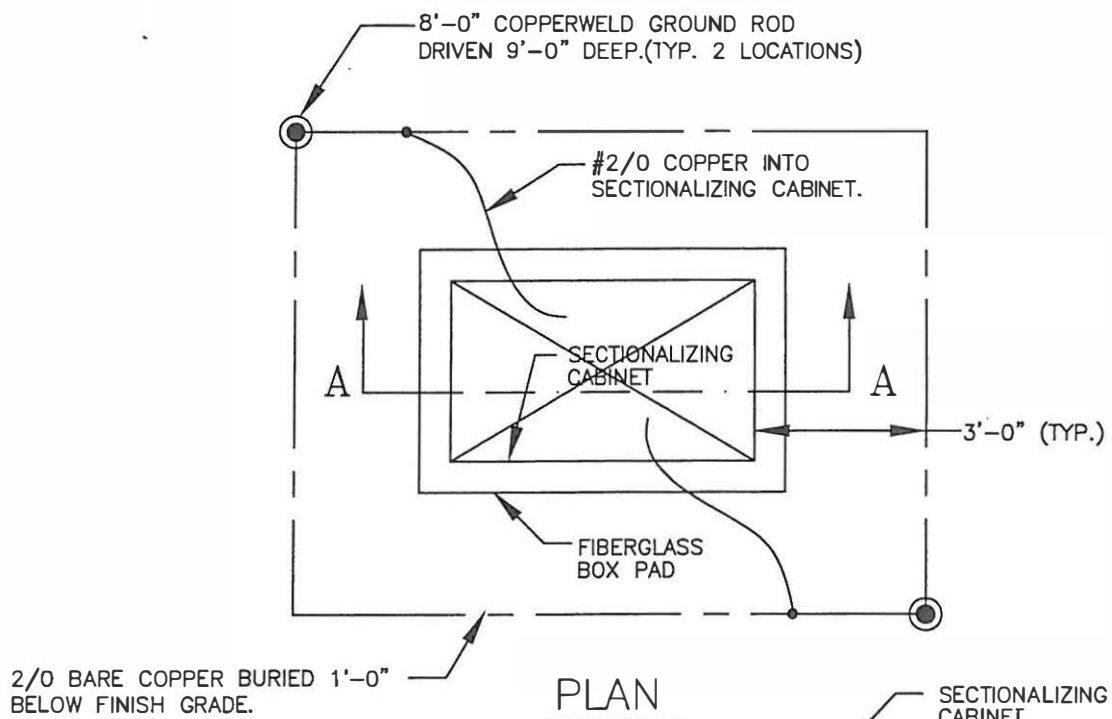

PLAN

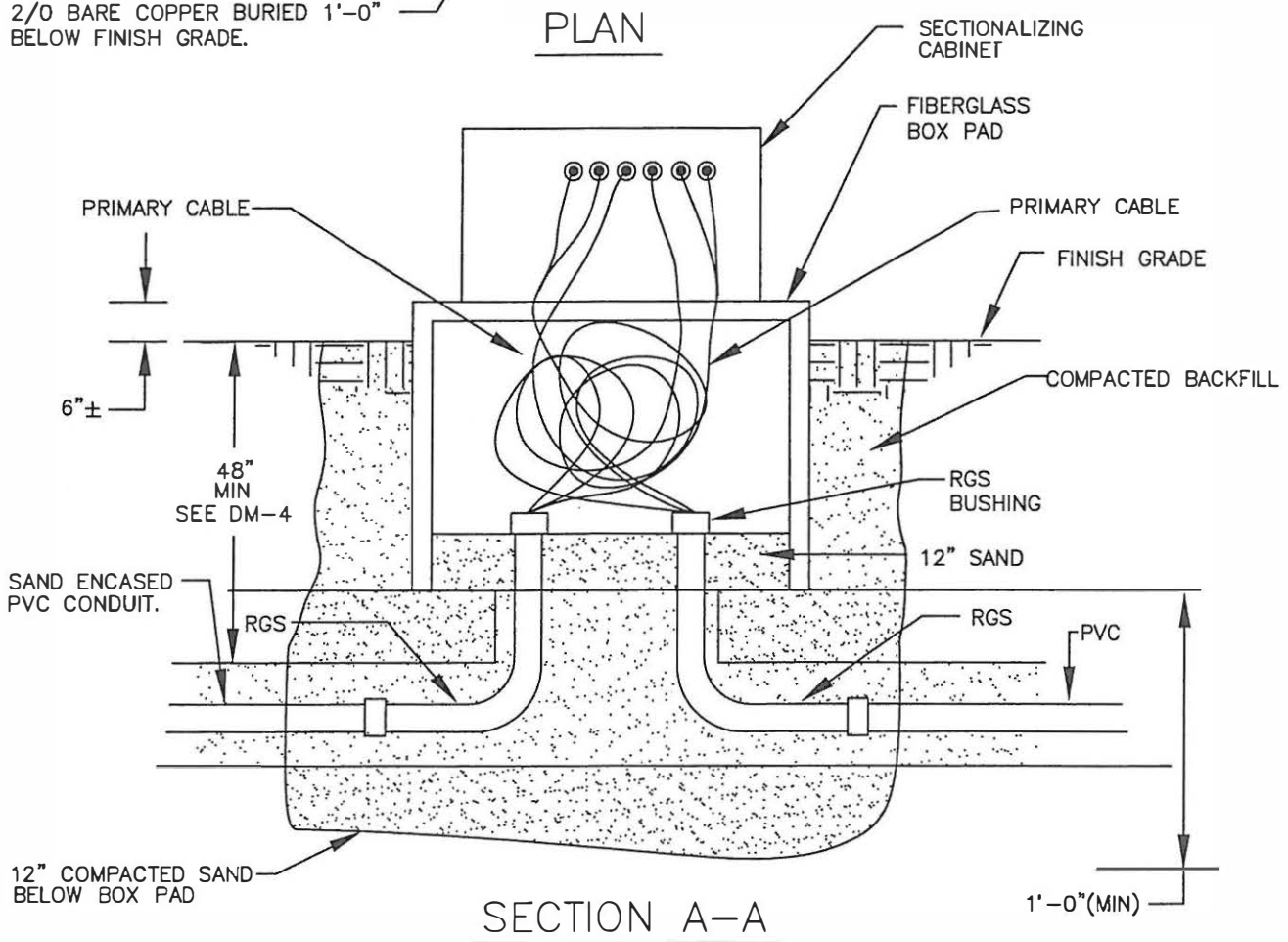

SECTION A-A

NOTES:

1. LOOP CABLES IN PAD TO PROVIDE SLACK FOR RETERMINATION IN THE EVENT OF ELBOW/CABLE FAILURE. ON THREE PHASE SYSTEMS, UTILIZE BOX PAD FOR PULLING UNUSED CABLE. LOOP CABLES IN PAD
2. GROUND CONNECTIONS BELOW GRADE TO BE COMPRESSION TYPE.

GMLD  
URD STANDARDS

DES	GW
DWN	DMM
CK'D	GW

SECTIONALIZING  
CABINET DETAIL  
(STANDARD CONDUIT INSTALLATION)

DATE:	2/28/00
SCALE:	NONE
DWG NO.	DM-2
FILE:	DM-2

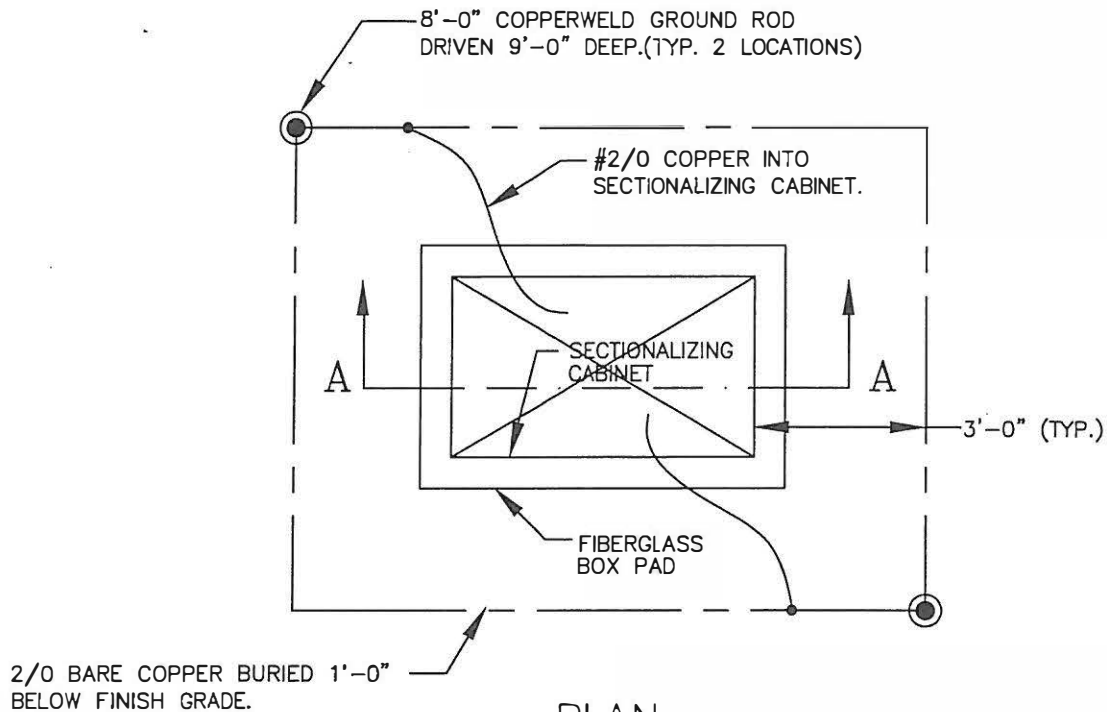

PLAN

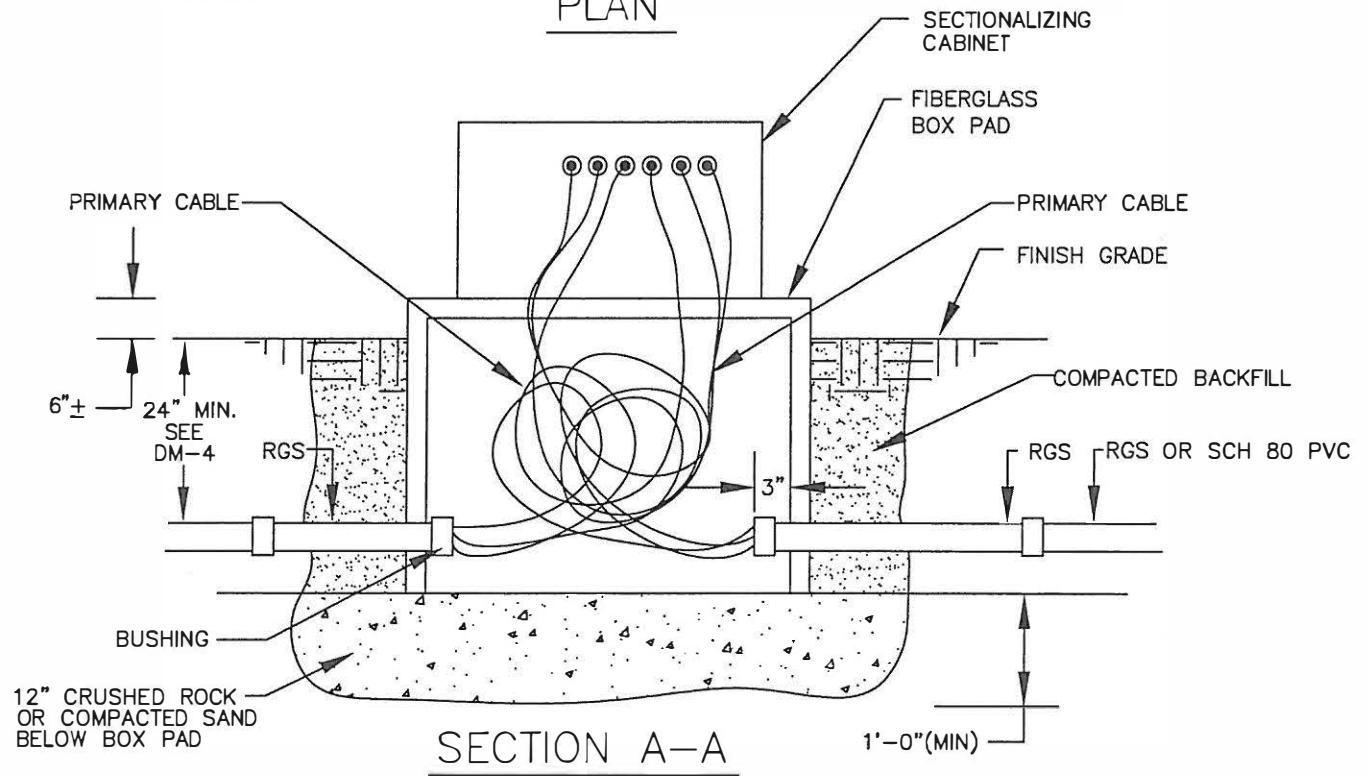

SECTION A-A

NOTES:

1. LOOP CABLES IN PAD TO PROVIDE SLACK FOR RETERMINATION IN THE EVENT OF ELBOW/CABLE FAILURE. ON THREE PHASE SYSTEMS, UTILIZE BOX PAD FOR PULLING UNUSED CABLE. LOOP CABLES IN PAD
2. GROUND CONNECTIONS BELOW GRADE TO BE COMPRESSION TYPE.

GMLD  
URD STANDARDS

DES	GW
DWN	DMM
CK'D	GW

SECTIONALIZING  
CABINET DETAIL  
(SHALLOW CONDUIT INSTALLATION)

DATE: 2/28/00
SCALE: NONE
DWG NO. DM-2A
FILE: DM-2A

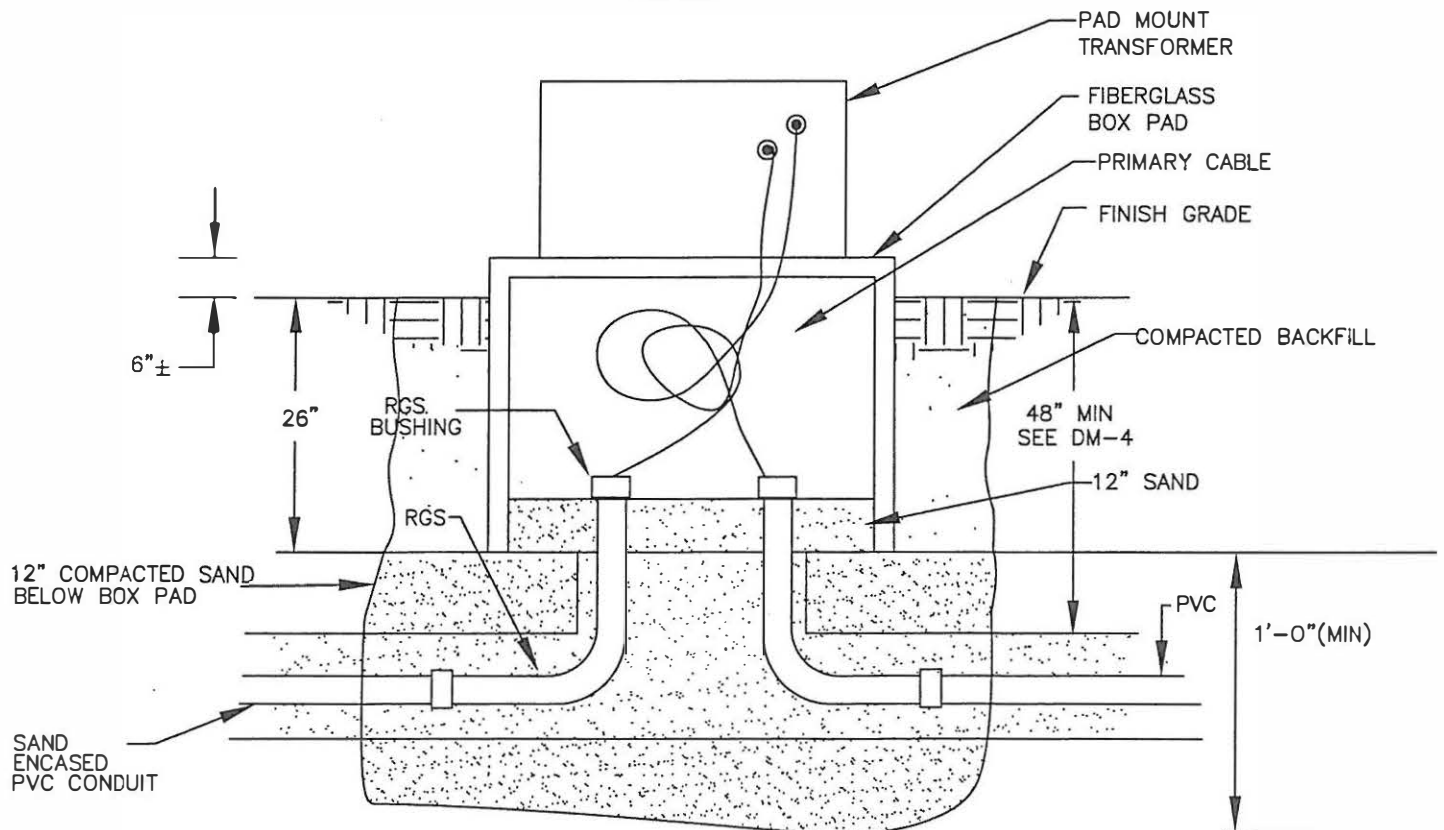
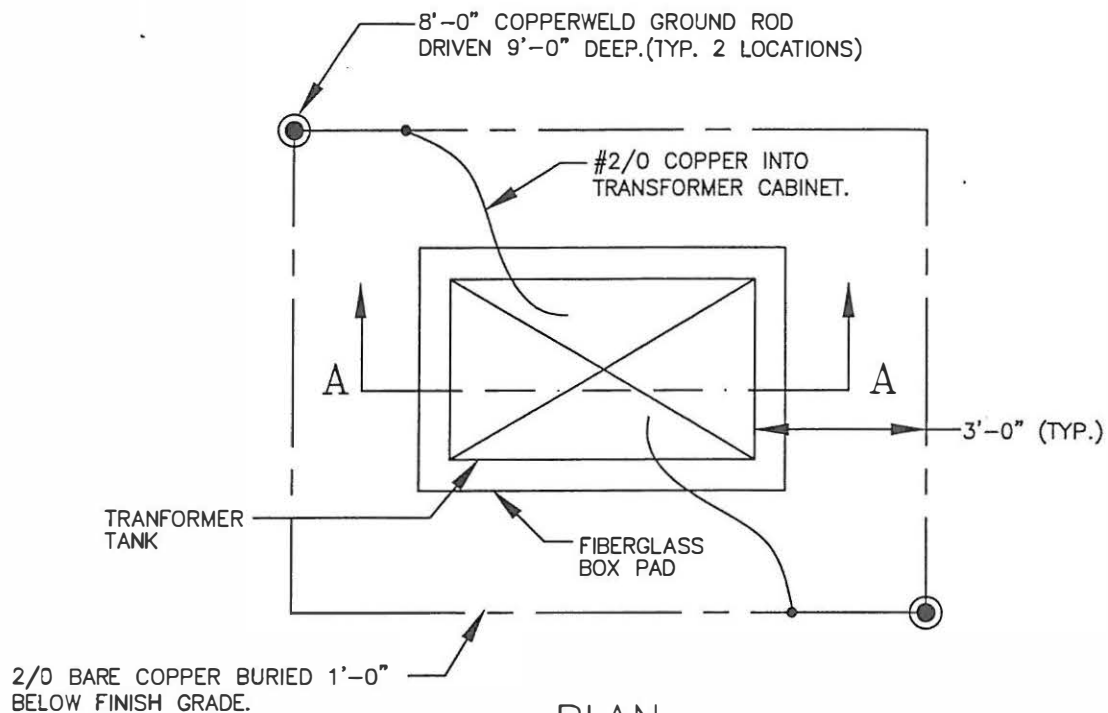

NOTES:

1. LOOP CABLES IN PAD TO PROVIDE SLACK FOR RETERMINATION IN THE EVENT OF ELBOW/CABLE FAILURE.
2. GROUND CONNECTIONS BELOW GRADE TO BE COMPRESSION TYPE.

GMLD  
URD STANDARDS

DES	GW
DWN	DMM
CK'D	GW

PAD MOUNTED  
TRANSFORMER DETAIL  
(STANDARD CONDUIT INSTALLATION)

DATE: 2/28/00

SCALE: NONE

DWG NO.

DM-3

FILE: DM-3

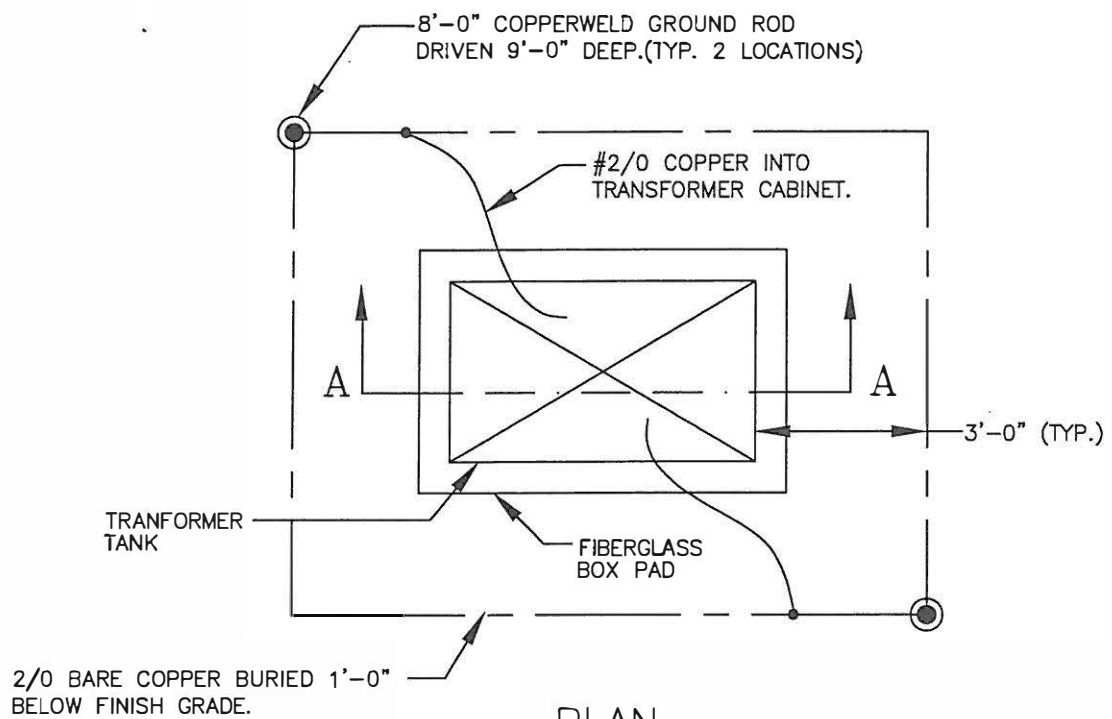

PLAN

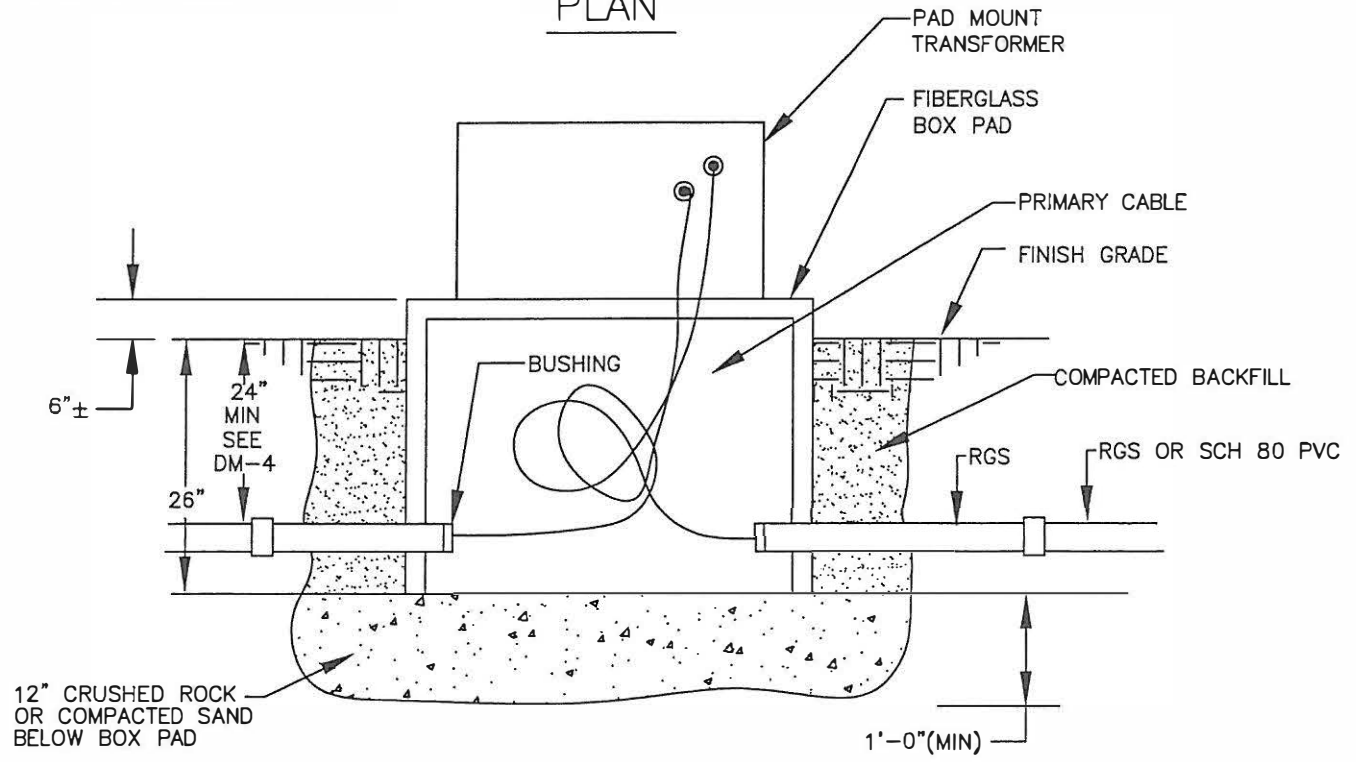

SECTION A-A

NOTES:

1. LOOP CABLES IN PAD TO PROVIDE SLACK FOR RETERMINATION IN THE EVENT OF ELBOW/CABLE FAILURE.
2. GROUND CONNECTIONS BELOW GRADE TO BE COMPRESSION TYPE.

GMLD  
URD STANDARDS

DES	GW
DWN	DM
CK'D	GW

PAD MOUNTED  
TRANSFORMER DETAIL  
(SHALLOW CONDUIT INSTALLATION)

DATE: 2/28/00
SCALE: NONE
DWG NO. DM-3A
FILE: DM-3A



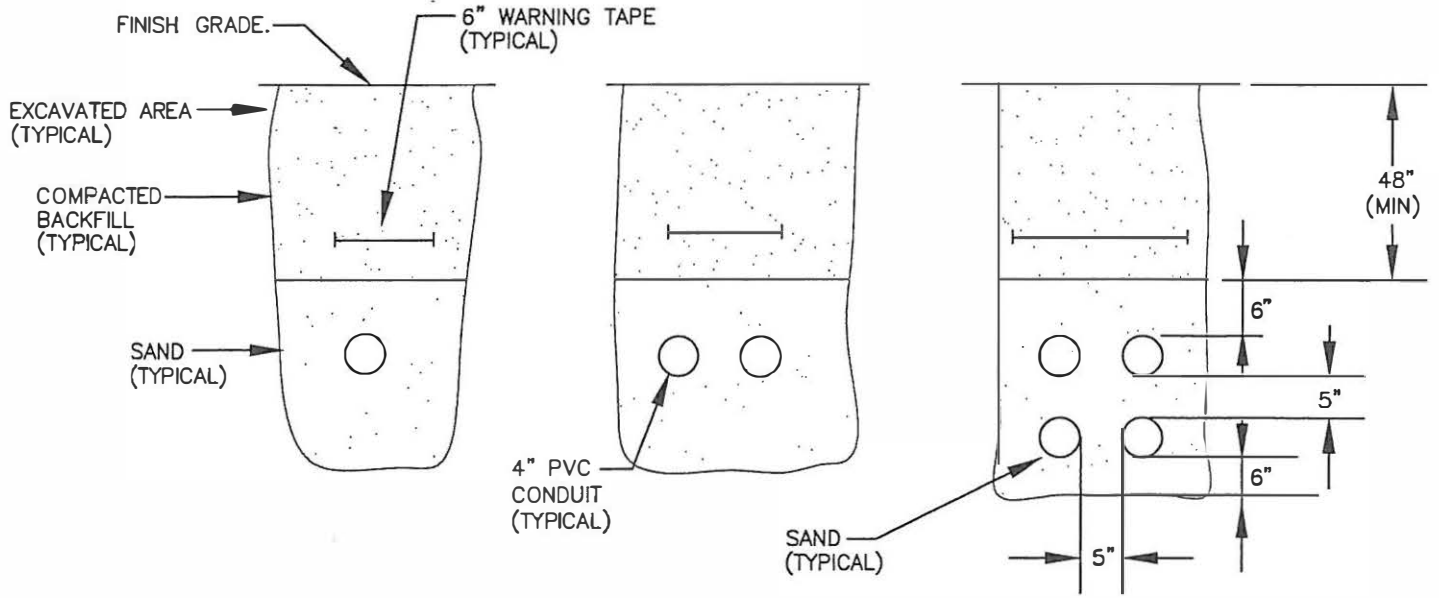

STANDARD INSTALLATION WITH SCH 40 PVC  
CONDUIT IN SAND

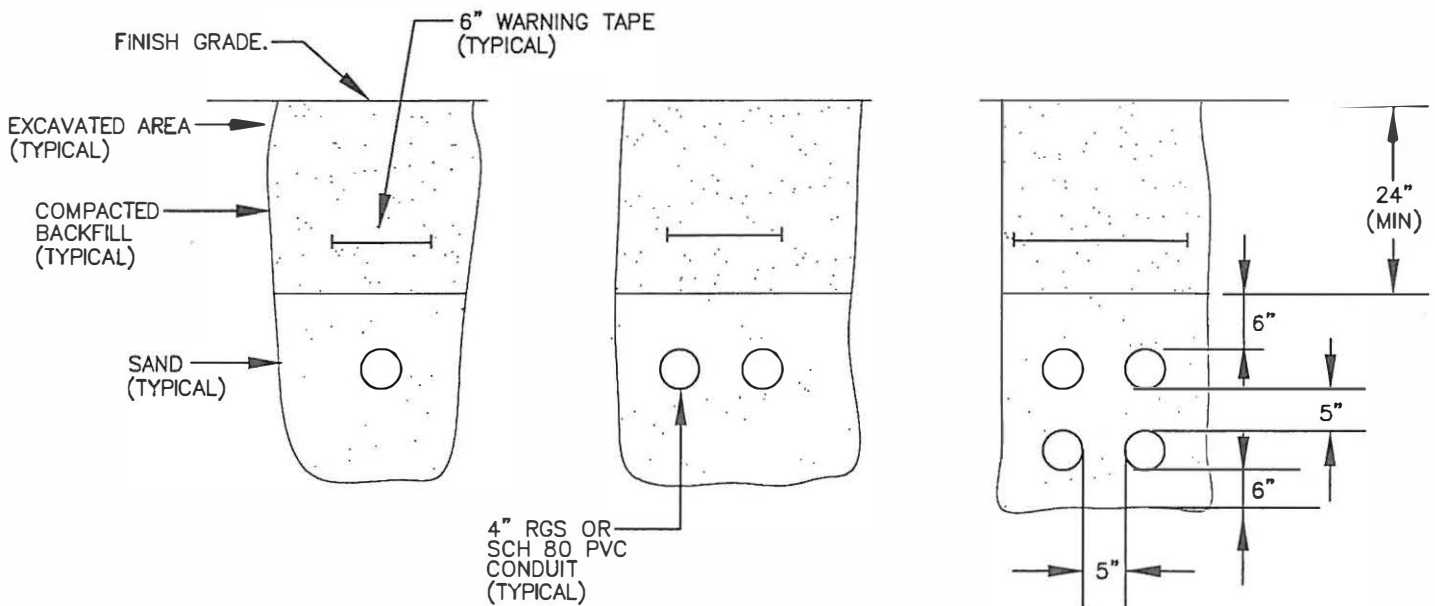

SHALLOW INSTALLATION WITH RGS OR SCH 80 PVC CONDUIT IN SAND

GMLD  
URD STANDARDS

DES	GW
DWN	DMM
CK'D	GW

PRIMARY UNDERGROUND  
CONDUIT DETAIL

DATE: 2/28/00
SCALE: NONE
DWG NO. DM-4
FILE DM-4

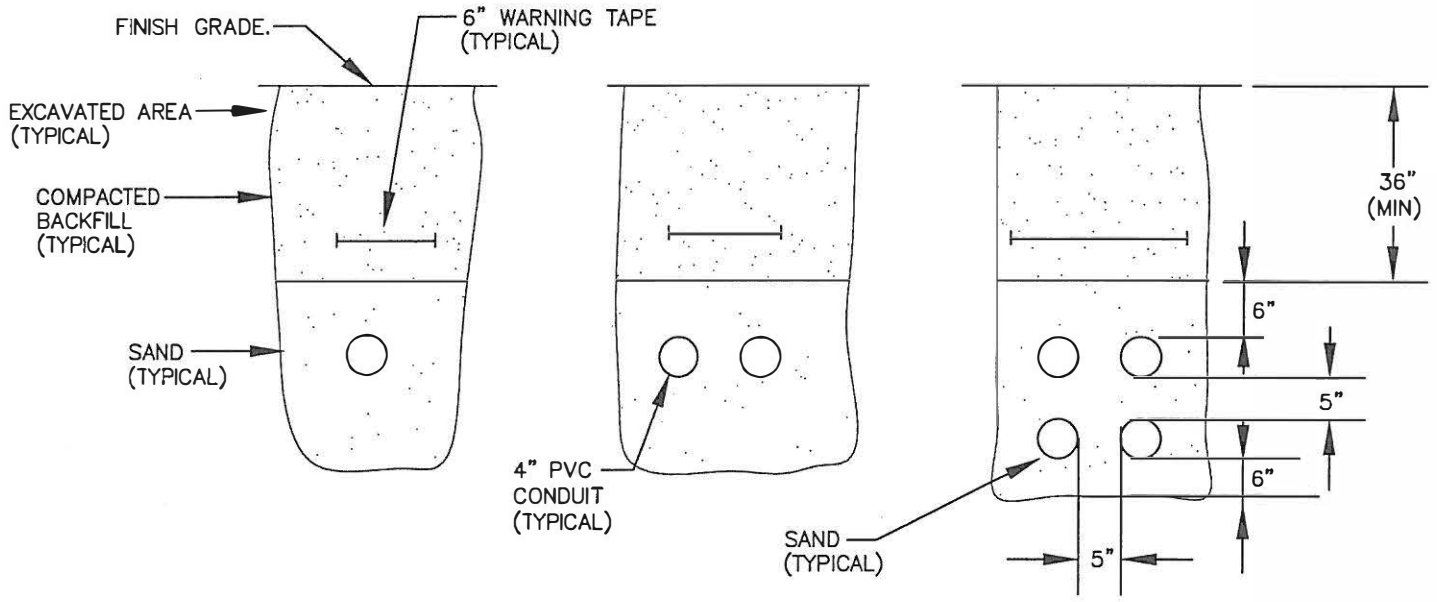

STANDARD INSTALLATION WITH SCH 40 PVC CONDUIT IN SAND

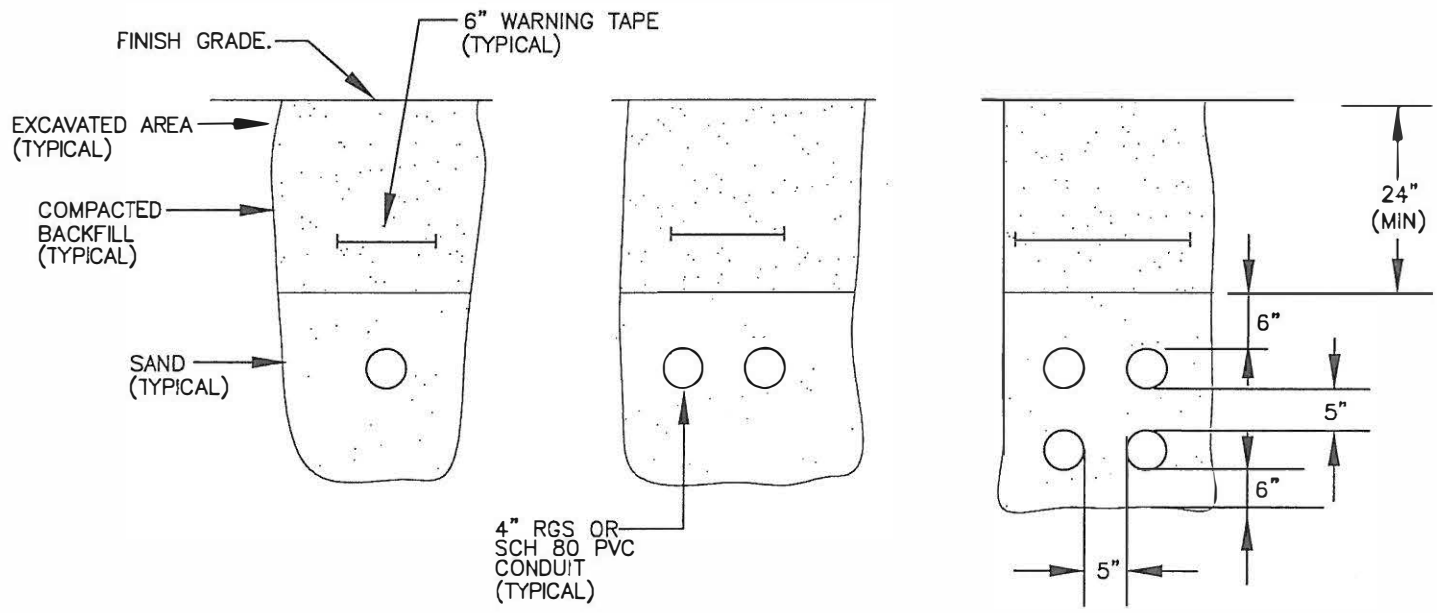

SHALLOW INSTALLATION WITH RGS OR SCH 80 PVC CONDUIT IN SAND

GMLD  
URD STANDARDS

DES	GW
DWN	DMM
CK'D	GW

SECONDARY UNDERGROUND  
CONDUIT DETAIL

DATE: 2/28/00
SCALE: NONE
DWG NO. DM-5
FILE: DM-5

URD STANDARDS

GMLD

DES  
GM  
DMN  
GM  
CKTD  
GM

PADMOUNT EQUIPMENT  
EASEMENT REQUIREMENTS  
(LARGEST PADMOUNT INSTALLATION)

DATE: 2/28/00  
SCALE: NONE  
DWG NO. DM-6  
FILE NO. 6

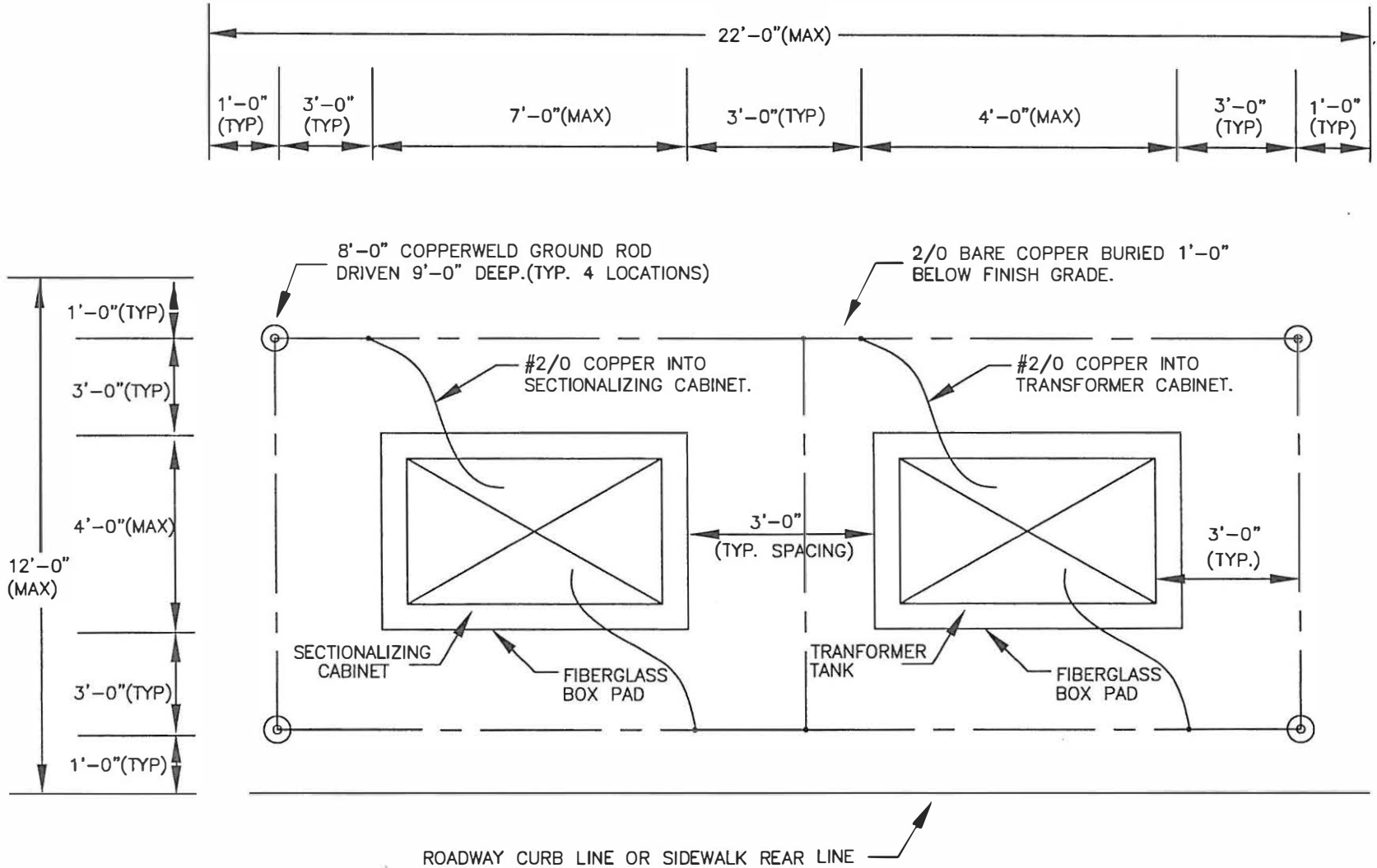

PLAN VIEW